

## 12400 SERIES

### BRASS BALL VALVE FEMALE X FEMALE NPT QUICK MOUNTING NICKEL PLATED WITH MOUNTING CONNECTION FOR ELECTRICAL ACTUATOR

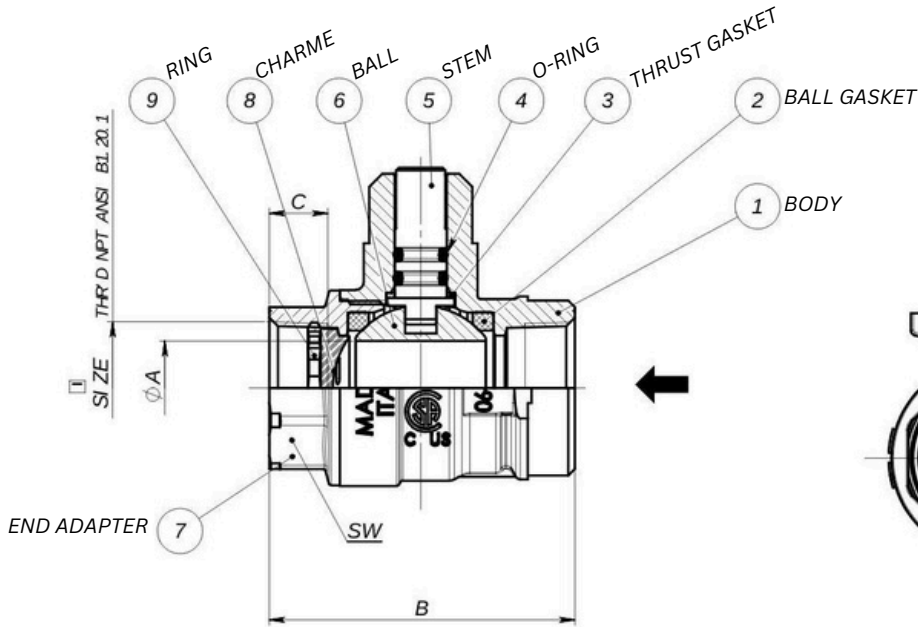

#### SPECIFICATION

BRASS BODY NICKEL PLATED CONNECTION FOR ELECTRICAL ACTUATOR

SIZES: 1/2"-2"

QUICK MOUNTING

CONNECTION: FEMALE X FEMALE NPT THREADED  
ANSI STANDARD B1.20.1

PRESSURE:  
145 PSI

TEMPERATURE: -4° F TO 266° F

APPLICATION: HOT AND COLD WATER,  
COMPRESSED AIR, OILS, ALL KINDS OF GASES, NON-CORROSIVE FLUIDS

DIRECTION OF FLOW: IN THE DIRECTION OF THE  
ARROW

**MADE IN ITALY**

#### COMPONENTS

N°	DESCRIPTION	MATERIAL
1	BODY	EGM.001
2	BALL GASKET	EGM.009
3	THRUST WASHER	EGM.009
4	O-RING	EGM.0.51 + EGM.014
5	STEM	EGM.064
6	BALL	EGM.064
7	END ADAPTER	EGM.001
8	CHARME	PLASTIC
9	RING	EGM.001

#### DIMENSIONS

INCHES

CODE	SIZE	DN	ØA	B	C	SW	PN
12400-005	1/2"	0.59	0.59	2.16	0.57	26	10
12400-007	3/4"	0.78	0.78	2.40	0.56	31	10
12400-010	1"	0.98	0.98	2.95	0.66	38	10
12400-012	1-1/4"	1.25	1.25	3.30	0.681	47	10
12400-015	1-1/2"	1.25	1.25	3.58	0.685	54	10
12400-020	2"	1.57	1.57	4.13	0.69	65	10